

Motorhome Insurance Policy

www.markerstudy.com

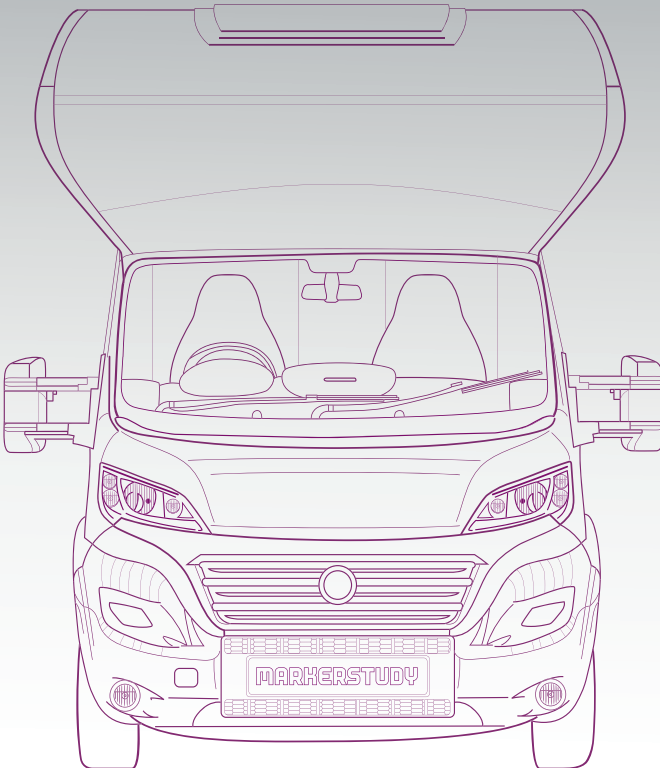

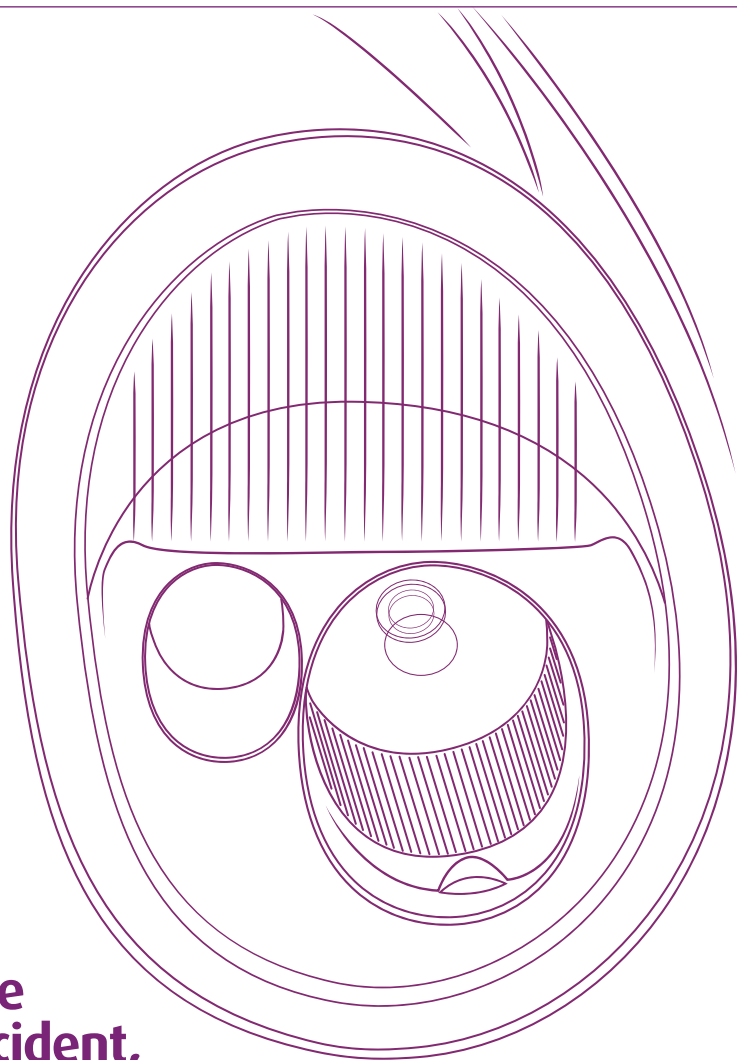

**If you have
had an accident,
call the 24 hour
Claims Helpline:
0344 873 8183**

Please call within 24 hours of the accident, but ideally within 1 hour.

Contents

Important Customer Information	3
What to do in the Event of an Accident	4
Introduction to Your Policy	5
Definitions	6 - 7
Insurance Provided - Guide to Policy Cover	8 - 9
Section A - Loss of or Damage to the Insured Vehicle	10 - 13
Section B - Loss of or Damage to the Insured Vehicle by Fire or Theft	14 - 16
Exceptions to Sections A & B	17 - 18
Section C - Liability to Other People	19
Exceptions to Section C	20
Section D - Provision of a Courtesy Vehicle	21
Section E - Personal Accident Benefits	22
Section F - Contents and Equipment	23 - 24
Section G - Medical Expenses	25
Section H - Glass Damage	26
Section I - Replacement Locks	27
Section J - Foreign Use of the Insured Vehicle	28 - 29
Section K - No Claim Bonus	30
Section L - Protected No Claim Bonus	31
Section M - Uninsured Driver and Vandalism Promise	31
Section N - Emergency Transport & Accommodation	32
Section O - Child Car Seat	32
General Exceptions	33 - 34
General Conditions	35 - 38
Our Service Commitment	39 - 40
How we use your information	41 - 43
Numbers to Call	44

Important Customer Information

3

Pages 3 and 4 are for your guidance and do not form part of the insurance contract.

You should keep a complete record of all information (including copies of letters) supplied to us in taking out this insurance.

So that you understand what you are covered for, please read this policy, the **Policy Schedule** (which may make reference to **endorsements**) and the **Certificate of Motor Insurance** very carefully. You should pay special attention to the General Exceptions and General Conditions of this policy.

The words or phrases shown under the Definitions section of this policy document commencing on page 6 have the same meaning whenever they appear in this policy document or in the **Certificate of Motor Insurance, policy schedule** or **endorsements**.

So that you can easily identify these words and phrases they are shown in bold print throughout this policy document.

If you have any questions, or the cover does not meet your needs or any of the details are incorrect you should notify us immediately via your **insurance intermediary**.

Guidance notes

There are useful guidance notes shown in shaded boxes throughout the policy document. The guidance notes do not form part of the insurance contract but are there to help you understand it. You should always read the guidance notes in conjunction with the whole of the policy document.

What to do in the Event of an Accident

Regardless of blame it is important that you take the following action:

Stop: Stop as soon as possible, in a safe place (if you have a warning triangle, place it well before the obstruction). If anybody has been injured, call the police and ambulance service.

Sketch: Make a quick sketch of the direction and final position of each vehicle (it is worth keeping a pen and paper in your vehicle).

Note down: You will need to make a note of:

- The vehicle registration number, name, address and telephone number of any other drivers involved in the accident.
- The number of passengers in each vehicle.
- The name and address of anyone who is injured (or suggesting they have been injured).
- The name, address and telephone number of any witnesses to the accident.
- The name, telephone number and constabulary of any police officer who attends the accident.

Take a photo: If you are able to do so, try and take photographs to support the positions of the vehicles and the extent of damage.

Provide: You must give your own details to anyone who has reasonable grounds for requesting them.

DO NOT: Do not admit responsibility, either verbally or in writing. Instead, simply supply your details along with your policy number to the other driver(s)/person(s) involved in the accident and ask him/her to call the claims advisors on **0344 873 8183**. By passing these details to the other person(s) involved in the accident you will give him/her the opportunity of obtaining assistance in progressing repairs and assisting with the provision of a courtesy vehicle if the circumstances of the accident warrant this.

If for any reason you have not been able to exchange details with other drivers or owners of property or you were in collision with an animal, you must report the accident to the police as soon as possible, and certainly within 24 hours of the accident.

Making contact following an incident.

0344 873 8183

Please call within 24 hours of the accident, but **ideally within 1 hour**. This is regardless of whether **you** wish to make a claim under the policy or not. **Delay in notification of an incident may invalidate your right to claim.**

Please quote **your** policy number and give all relevant information about the incident. If **your** claim is due to theft, attempted theft or vandalism **you** must also inform the police and obtain a crime reference number.

Your claim and claims made against you, will be dealt with as quickly and fairly as possible. Please read the General Conditions in this policy booklet.

For our joint protection telephone calls may be recorded and monitored by us.

Introduction to Your Policy

Thank you for choosing to purchase an Insurance policy arranged by Markerstudy Insurance Services Limited.

This Policy Document is evidence of a legally binding contract of insurance between you (the Insured) and us (Markerstudy Insurance Services Limited on behalf of the authorised insurer, details of which can be found on your **certificate of motor insurance**). This contract is entered into on the basis that:

- you have taken all reasonable care to answer all questions asked honestly, accurately and to the best of your knowledge; and
- any other information given either verbally or in writing by you, or on your behalf at the time you applied for insurance is also complete; and
- the information supplied has been given honestly and to the best of your knowledge and belief.

The information that you have given to us is shown on your signed **proposal form** or **statement of fact** or **statement of insurance** but will also include further information given either verbally or in writing by you or on your behalf at the time you applied for insurance.

You must read this **Policy Document**, the **Policy Schedule** and the **Certificate of Motor Insurance** together. The **Policy Schedule** tells you which sections of the policy apply. Please check all three documents carefully to make certain they give you the cover you want.

We have arranged to insure you against liability, loss or damage that may occur within the **geographical limits** of the policy during any **period of insurance** for which you have paid, or agreed to pay the premium. The cover provided is subject to the terms, conditions and exceptions contained in this policy document or in any **endorsement** applying to this policy document.

Nobody other than you (the Insured), us (Markerstudy Insurance Services Limited) or the insurer has any rights that they can enforce under this contract except for those rights that they have under road traffic law in any country in which this insurance applies.

Unless specifically agreed otherwise, this insurance shall be subject to English Law.

The terms and conditions of this policy and all other information concerning this insurance are communicated to you in the English language and we undertake to communicate in this language for the duration of the policy.



Signed for and on behalf of the Insurers by:

Gary Humphreys
Group Underwriting Director

Markerstudy Insurance Services Limited

Markerstudy Insurance Services Limited is registered in England and Wales (No. 2135730) and authorised and regulated by the Financial Conduct Authority (No. 475572).

Registered office 45 Westerham Road, Bessels Green, Sevenoaks, Kent TN13 2QB

Several Liabilities Notice

The obligations of the co-insurers under contracts of insurance to which they subscribe are several and not joint and are limited solely to the extent of each insurer's individual subscription. If one of the insurers does not for any reason satisfy all or part of its obligations the other insurers will not be responsible for the defaulting insurer's obligations.

Financial Services Compensation Scheme

The Financial Services Compensation Scheme covers this policy. **You** may be entitled to compensation from this scheme if **we** cannot meet **our** liabilities under this policy. Further information about compensation scheme arrangements is available at **www.fscs.org.uk** or by telephoning **0207 741 4100**.

Definitions

The words or phrases shown below have the same meaning whenever they appear in this policy document or in the Certificate of Motor Insurance, Policy Schedule or Endorsements. So that you can easily identify these words and phrases they are shown in bold print throughout this policy document.

Certificate of Motor Insurance

A document, which is legal evidence of your insurance and is required by law and forms part of this contract of insurance. It shows the **insured vehicle's** registration number, who may drive it and what it may be used for. The **Certificate of Motor Insurance** must be read with this policy document.

Endorsements

A change in terms of this insurance, which replaces or alters the standard insurance policy wording.

Equipment

Additional/supplementary parts to **your insured vehicle** not directly related to its function as a vehicle, other than items specifically defined as contents. **Equipment** includes free standing awnings (whilst attached to **your insured vehicle**), toilet tents, gas bottles, generators, utensils and other general camping **equipment**.

Excess

An amount you have to pay towards the cost of a claim under this insurance. You have to pay this amount regardless of the circumstances leading to the claim.

Geographical Limits

The United Kingdom of Great Britain & Northern Ireland, the Isle of Man and the Channel Islands.

Insurance Intermediary

The intermediary who has placed this insurance with us, acting on your behalf as your agent and through whom all matters concerning this insurance are handled.

Insured Vehicle

The Motorhome, the details and registration number of which are shown in the **Policy Schedule**. Permanently fitted accessories (other than **in-vehicle entertainment, communication and navigation equipment**) are included within this definition.

In-vehicle Entertainment, Communication and Navigation Equipment

Permanently fitted radios, cassette, MP3, compact disc or DVD players, telephones, CB radios and visual navigation equipment. *Portable items (such as radar detection equipment, personal digital assistants or portable GPS navigators), cassette tapes, memory cards, compact discs or DVDs are not included within this definition.*

Definitions (continued)

Market Value

The cost of replacing the **insured vehicle** at the time of loss or damage compared with one of the same make, model, specification and condition. If the **insured vehicle** was first registered as new in a country other than those contained within the **geographical limits** any assessment of **market value** will take into account that the **insured vehicle** has been individually imported into a country contained within the **geographical limits** but will not include any delivery costs incurred at the time of importation. The **market value** will be assessed by an automotive engineer in conjunction with the published trade guides at the time of loss.

Panoramic roof

A vehicle roof system manufactured as single or multiple glass, or equivalent, panel(s) designed to cover the entire passenger compartment or the majority of it.

Partner

Your husband, wife, civil partner, common law partner or someone you are living with as if you are married to them.

Period of Insurance

The period between the effective date and expiry date shown on the **Policy Schedule** and any subsequent period for which **we** accept renewal of the insurance.

Personal belongings

Personal property within the **insured vehicle** including clothing, portable audio equipment, multimedia equipment, personal computers, satellite navigation systems not permanently fitted to the **insured vehicle**.

Policy Schedule

The document which shows details of the insured policyholder and insurance protection provided and forms part of this contract of insurance.

Proposal Form

The application for insurance and declaration completed by you or on your behalf and signed by you. **We** have relied on the information provided on this form in entering into this contract of insurance.

Statement of Fact or Statement of Insurance

The form that shows the information that you gave us or that was given on your behalf at the time you applied for insurance. **We** have relied on the information provided on this form in entering into this contract of insurance.

Terrorism

Terrorism as defined in the **Terrorism Act 2000** or any subsequent amendment.

Third party

Any person, including the legal owner of the **insured vehicle**, who makes a claim against anyone insured under this policy.

Unattended

Where you or no person authorised by you are present in the **insured vehicle**, in charge of the **insured vehicle** or are not in a position to prevent unauthorised interference with the **insured vehicle**.

We/Us/Our

Markerstudy Insurance Services Limited for and on behalf of the insurance company as specified in the **Certificate of Motor Insurance**.

Written down value

The value placed on your **insured vehicle** by the company who leased the vehicle to you under a lease agreement.

You/Your

The insured policyholder named in the **Policy Schedule** and **Certificate of Motor Insurance**.

Insurance Provided - Guide to Policy Cover

The level of cover provided by this insurance is shown on **your Policy Schedule**.

The sections of this Insurance Policy that apply for each level of cover are as shown below. Cover is subject to any **endorsement** shown on your **Policy Schedule**.

Comprehensive

Sections A to K and M, N and O of this Insurance Policy Apply*

Third Party Fire and Theft

Sections B, C, J, and K of this Insurance Policy apply*

Third Party Only

Sections C, J, and K of this Insurance Policy apply*

The General Exceptions and General Conditions of this Insurance Policy apply to all levels of cover.

*Section L may also apply if shown on **your Policy Schedule**

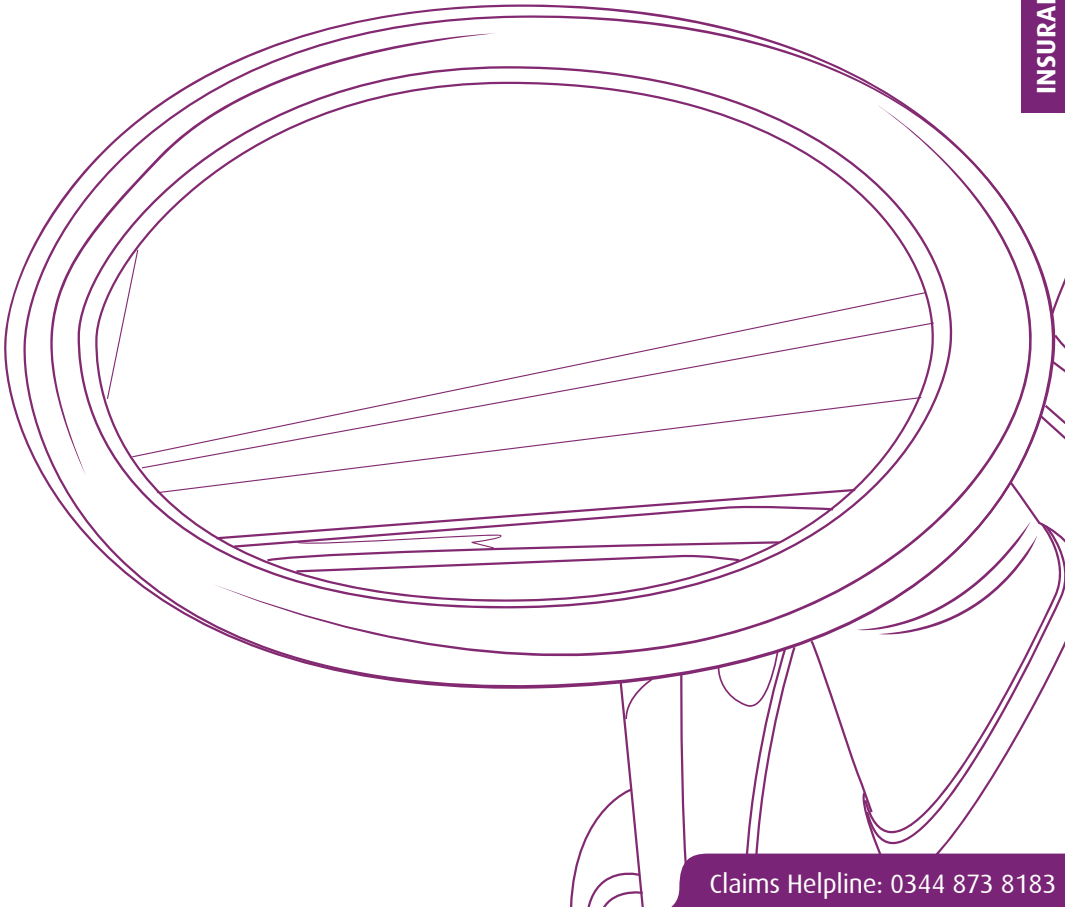

Insurance Provided - Guide to Policy Cover (continued)

Notification of changes

To keep **your** insurance up to date please notify **us** straight away via **your insurance intermediary** about changes which affect **your** cover.

Some examples are:

- A change of vehicle or **you** have purchased another vehicle to which **you** want **your** existing cover to apply.
- The **insured vehicle** is changed or modified from the manufacturer's standard specification or **you** intend to change or modify it (including the addition of optional fit accessories such as spoilers, skirts, alloy wheels etc).
- A change in the use of the **insured vehicle**.
- A change relating to the ownership of the **insured vehicle**.
- The **insured vehicle** has been stolen or is involved in an accident no matter how trivial.
- If the **insured vehicle** is likely to exceed the annual mileage declared at the commencement or renewal of the policy for which **you** may have received a premium discount.
- Any change in the main user of the **insured vehicle**.
- **You** wish a new driver to be covered.
- Someone who drives the **insured vehicle** is convicted of an offence (whether motor related or not) or fixed penalty or other licence endorsement or suffers from a medical condition or has a claim on another policy.
- Someone who drives the **insured vehicle** has any police enquiry or prosecution pending (note – if **you** have been stopped by the police a prosecution may be pending and must be disclosed).
- A change of occupation (full or part-time) by **you** or any other driver.
- A change of postal address.

- A change of garaging facilities and/or where the **insured vehicle** is normally kept overnight.
- The security system fitted to the **insured vehicle** is no longer in operation.
- Any Advanced Driver Assistance Systems fitted to the **insured vehicle** that require recalibration or are not in working order.

This is not a full list and if **you** are in any doubt **you** should advise **your insurance intermediary** for **your** own protection.

If the information provided by **you** is not complete or accurate:

- **we** may cancel **your** policy and refuse to pay any claim, or
- **we** may not pay any claim in full, or
- **we** may revise the premium and/or change the compulsory **excess**, or
- the extent of the cover may be affected.

Guidance notes - Notification of changes

The premium that you pay is based on information you supplied at the inception or renewal date of this insurance policy.

If your circumstances, or the circumstances of any driver covered by this policy change, then the premium needs to be recalculated to ensure we are collecting the correct premium for the risk.

It is important that you notify your insurance intermediary immediately of any changes such as those examples given under Notification of changes.

If you fail to supply details of changes or the information supplied by you is not complete or accurate then:

- we may cancel your policy and refuse to pay any claim, or
- we may not pay any claim in full, or
- we may revise the premium and/or change the compulsory excess, or
- the extent of the cover may be affected.

Section A - Loss of or Damage to the Insured Vehicle

This section only applies if the cover shown on **your Policy Schedule** is Comprehensive.

What is covered

We will cover **you** against loss or damage to the **insured vehicle** (less any **excess** that applies) caused accidentally or as a result of malicious damage or vandalism. Loss or damage more specifically covered under Section B of this policy is excluded under this section of the policy. We will also cover **you** for damage to sunroofs, **panoramic roofs**, lights/reflectors, folding rear windscreen assemblies or any permanently fitted accessories including glass contained within hard tops, under this section.

Loss of or damage to **your insured vehicle's** spare parts and accessories are also covered as long as they are kept in or permanently on **your insured vehicle** or in **your** own private garage and fall within the maximum amount **we** will pay.

If the **insured vehicle** is fitted with Advanced Driver Assistance Systems (ADAS) **we** will pay for the recalibration of cameras or sensors fitted to the **insured vehicle** to operate these systems, if required, following an insured incident under this section.

Cover also applies under this section while the **insured vehicle** is in the custody of a member of the motor trade for servicing or repair.

Under this section we may either:

- pay for the damage to the **insured vehicle** to be repaired; or
- with **your** agreement provide a replacement vehicle; or
- pay an amount of cash equivalent to the loss or damage.

The most **we** will pay will be either:

- the **market value** of the **insured vehicle** immediately before the loss; or
- the cost of repairing the **insured vehicle**, whichever is the lower amount.
- the **written down value, agreed value or market value**, whichever is lower, if **your insured vehicle** is under a lease agreement.

If the **insured vehicle** is subject to a hire purchase agreement, **we** will pay any money

owed to that company first and then pay any remaining money to **you**. If **you** have acquired the **insured vehicle** through lease or contract hire, **we** will pay the lease or contract hire company either the **market value or written down value** of the **insured vehicle**, or the amount required to settle the agreement, whichever is less.

We will not pay more than the **market value, written down value** or agreed value of the **insured vehicle** at the time of the loss less the total of the **excesses** shown in the **policy schedule**. We will also pay the costs for the protection, removal and storage of the **insured vehicle** following an accident and delivery after repair to **your** address.

We are not liable for any amount **you** are contractually obliged to pay under any lease or finance agreement, **you** have entered into, over and above the cost of replacing **your vehicle**.

If the **insured vehicle** is deemed to be beyond economical repair or settlement is agreed under the 'New vehicle cover' sub-section the damaged vehicle becomes **our** property once a claim is met under the policy. **You** must send us the vehicle registration document and valid MOT certificate if one is required by law before **we** are able to meet the claim.

In-vehicle entertainment, communication and navigation equipment

We will cover the cost of replacing or repairing the **insured vehicle's entertainment, communication and navigation equipment** up to the following amounts less the **excess** as shown on the **policy schedule**:

- Unlimited for equipment fitted as original equipment by the manufacturer; or
- £500 for the **insured vehicle's entertainment, communication and navigation equipment** not fitted by the manufacturer, provided it is permanently fitted to the **insured vehicle**.

Any amount payable in respect of **in-vehicle entertainment, communication and navigation equipment** will not exceed the value of the equipment at the time of the loss or damage after making a reasonable deduction for wear and tear.

Section A - Loss of or Damage to the Insured Vehicle (continued)

New vehicle cover

We may replace the **insured vehicle** with one of the same make, model and specification if;

- The loss or damage happens within twelve months from the date the **insured vehicle** was first registered; and
- **You** or **your partner** are the first and only registered keeper of the vehicle (or the second registered keeper if the first registered keeper is the manufacturer or supplying dealer and the delivery mileage is under 250 miles); or
- The vehicle is owned by a Lease Company who are the first and only registered keeper of the vehicle and they are in agreement that a replacement vehicle can be supplied; and
- The cost of repair is valued at more than 60% of the cost of buying an identical new vehicle at the time of the loss or damage (based on the United Kingdom list price); and
- The vehicle has covered less than 10,000 miles; and
- The vehicle was supplied as new from within the **geographical limits**.

In these circumstances **we**, if asked by **you**, may replace the **insured vehicle** (and pay delivery charges) with a new vehicle of the same make, model and specification. **We** can only do this if a replacement vehicle is available in the **geographical limits** and anyone else who has an interest in the vehicle agrees.

If a replacement vehicle of the same make, model and specification is not available, **we** may, where possible, provide a similar vehicle of identical list price. If this is not acceptable to **you** **we** will not pay more than the **market value** or **written down value** of the **insured vehicle** at the time of the loss.

Once a settlement has been agreed in accordance with this new vehicle cover, the damaged vehicle becomes **our** property.

If the **insured vehicle** is the subject of a Hire Purchase or Lease Agreement **we** will only agree settlement on the basis of this new vehicle cover if **we** have the agreement of the

Hire Purchase or Lease Company as owner of the **insured vehicle**.

Repairs

Contact the Claims Helpline as soon as possible if **your insured vehicle** is damaged as a result of an incident covered by this policy. Claims advisers are there to assist **you** and will guide **you** through the repair process.

If parts required for repairing the **insured vehicle** are not available in any country within the **geographical limits** our liability for those parts shall not exceed the manufacturers' last United Kingdom list price or if not listed the price of those parts for the nearest comparable vehicle available in the United Kingdom.

We will not pay the cost of importing parts that are not available in any country within the **geographical limits**.

We may at **our** option use parts that have not been supplied by the original manufacturer to repair the **insured vehicle**. These parts will be subject to the **part manufacturer's** guarantee.

We will not pay the cost of any repair or replacement which improves the **insured vehicle** to a better condition than it was in before the loss or damage. If this does happen **you** must make a contribution towards the cost of repair or replacement. **You** may be required to contribute to the cost of replaced items such as exhausts or tyres.

Guidance Notes – Finance or Lease agreement

If your insured vehicle is the subject of a finance or lease agreement and your vehicle is deemed to be damaged beyond economic repair due to a covered loss under the policy the market value or written down value placed on your insured vehicle may not be sufficient to satisfy that agreement.

This policy does not cover any amount you are contractually obliged to pay under any lease or finance agreement, you have entered into, over and above the cost of replacing your vehicle.

We would recommend that you discuss any concerns that you may have with your insurance intermediary who may be able to supply you with details of products available to cover any shortfall.

The young and inexperienced driver **excess** applicable at the time of loss or damage is determined by the age or driving experience of the person driving/in charge of the **insured vehicle** at the inception date or last renewal date of the policy whichever is the later. The amounts shown are in addition to any other **excesses** shown elsewhere in this **policy document** or on **your Policy Schedule** or in any **endorsement**.

Young and Inexperienced Driver Excesses

You will be responsible for paying the following amounts while the **insured vehicle** is being driven by, is in the charge of or was last in the charge of the categories of driver listed below:

Age or experience of person driving, in charge of or last in charge of the insured vehicle	Amount of Excess
Aged 20 years and under	£300
Aged 21 to 24 years inclusive	£200
Aged 25 years and over but: <ul style="list-style-type: none"> • Who holds a provisional driving licence; or • who holds an international driving licence; or • has held a full driving licence to drive a private motor car issued either in a country contained within the geographical limits or a member country of the European Union but for less than one year. 	£150

Section A - Loss of or Damage to the Insured Vehicle (continued)

Protection and Recovery

If the **insured vehicle** cannot be driven following an incident leading to a valid claim under this section, **we** will pay:

- the cost of its protection and removal to the nearest competent repairer or nearest place of safety; and
- the cost of re-delivery after repairs to **your** home address; and
- the cost of storage of the **insured vehicle** incurred with **our** written consent.

If the **insured vehicle** is damaged beyond economical repair **we** will arrange for it to be stored safely at premises of **our** choosing. **You** should remove **your personal belongings** from the **insured vehicle** before it is collected from **you**.

In the event of a claim being made under the policy **we** have the right to remove the **insured vehicle** to an alternative repairer, place of safety or make **our** own arrangements for re-delivery at any time in order to keep the cost of the claim to a minimum.

Guidance Notes – Flood Advice

- If possible move your Motorhome to a safer place out of the reach of floodwater before the flood strikes (e.g. to higher ground).
- Do not attempt to drive your Motorhome through floodwater as it is inevitable that this will damage your engine particularly if your Motorhome has a diesel engine or turbo charger.
- If your Motorhome is submerged do not try to start the engine. If possible get your Motorhome pushed or towed out of the water and allow it to dry out. You may be lucky and the water may not have penetrated sufficiently to ruin the engine.
- Repairs to the insured vehicle resulting from flood damage are covered if your policy cover is comprehensive but claims will be subject to the policy excesses. A comprehensive policy will also pay for towing as well as damage to upholstery, carpets and stereo systems resulting from flooding but only up to the limits shown within this document.

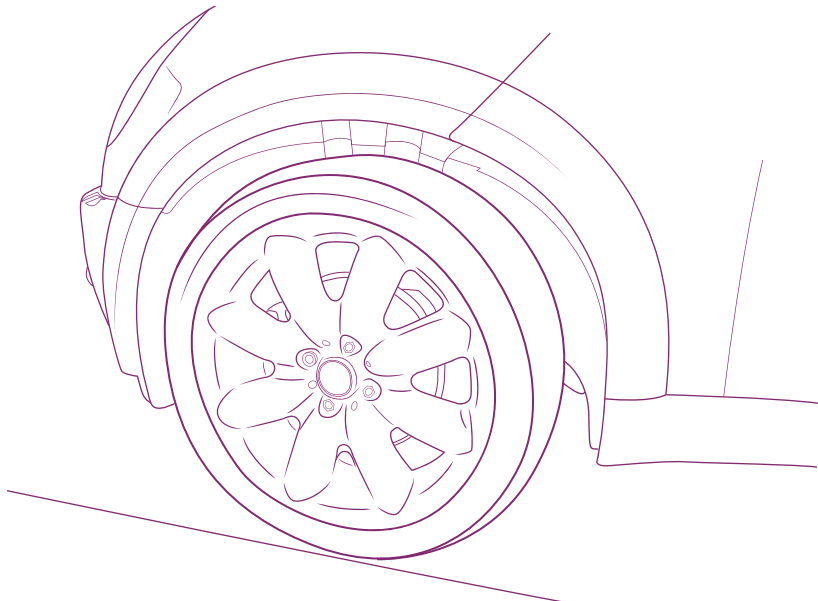

Section B - Loss of or Damage to the Insured Vehicle by Fire or Theft

This section only applies if the cover shown on **your Policy Schedule** is either Comprehensive or Third Party Fire and Theft.

What is covered

We will cover **you** against loss of or damage to the **insured vehicle** (less any **excess** that applies) caused by fire, lightning, explosion, theft or attempted theft.

If the **insured vehicle** is fitted with Advanced Driver Assistance Systems (ADAS) **we** will pay for the recalibration of cameras or sensors fitted to the **insured vehicle** to operate these systems, if required, following an insured incident under this section.

Cover also applies under this section while the **insured vehicle** is in the custody of a member of the motor trade for servicing or repair.

Under this section we may either:

- pay for the damage to the **insured vehicle** to be repaired; or
- with **your** agreement provide a replacement vehicle; or
- pay an amount of cash equivalent to the loss or damage.

The most we will pay will be either:

- the **market value** of the **insured vehicle** immediately before the loss; or
- the cost of repairing the **insured vehicle**, whichever is the lower amount.
- the **written down value, agreed value or market value**, whichever is lower, if **your insured vehicle** is under a lease agreement.

If the **insured vehicle** is subject to a hire purchase agreement, **we** will pay any money owed to that company first and then pay any remaining money to **you**. If **you** have acquired the **insured vehicle** through lease or contract hire, **we** will pay the lease or contract hire company either the **market value** or **written down value** of the **insured vehicle**, or the amount required to settle the agreement, whichever is less.

We will not pay more than the **market value** or **agreed value** of the **insured vehicle** at the time of the loss less the total of the **excesses** shown in the **policy schedule**.

We will also pay the costs for the protection, removal and storage of the **insured vehicle** following a covered loss and delivery after repair to **your** address.

We are not liable for any amount **you** are contractually obliged to pay under any lease or finance agreement, **you** have entered into, over and above the cost of replacing **your** vehicle.

If the **insured vehicle** was not first registered from new in any country within the **geographical limits** **we** will not pay more than the purchase price paid by **you** at the time that **you** purchased the **insured vehicle**.

If the **insured vehicle**:

- is stolen and has not been recovered at the time of settlement; or
- is deemed to be beyond economical repair, as a result of loss covered under this section of the policy, the lost or damaged vehicle becomes our property once a claim is met under the policy.

You must send **us** the vehicle registration document and valid MOT certificate (if one is required by law) before **we** are able to meet the claim.

In-vehicle entertainment, communication and navigation equipment

We will cover the cost of replacing or repairing the **insured vehicle's** **entertainment, communication and navigation equipment** up to the following amounts less the **excess** as shown on the **policy schedule**:

- Unlimited for equipment fitted as original equipment by the manufacturer; or
- £500 for the **insured vehicle's** **in-vehicle entertainment, communication and navigation equipment** not fitted by the manufacturer, provided it is permanently fitted to the **insured vehicle**.

Section B - Loss of or Damage to the Insured Vehicle by Fire or Theft (continued)

Any amount payable in respect of **in-vehicle entertainment, communication and navigation equipment** will not exceed the value of the equipment at the time of the loss or damage after making a deduction for wear and tear.

New vehicle cover

We may replace the **insured vehicle** with one of the same make, model and specification if;

- The loss or damage happens within twelve months from the date the **insured vehicle** was first registered; and
- **You** or **your partner** are the first and only registered keeper of the vehicle (or the second registered keeper if the first registered keeper is the manufacturer or supplying dealer and the delivery mileage is under 250 miles); or
- The vehicle is owned by a Lease Company who are the first and only registered keeper of the vehicle and they are in agreement that a replacement vehicle can be supplied; and
- The cost of repair is valued at more than 60% of the cost of buying an identical new vehicle at the time of the loss or damage (based on the United Kingdom list price); and
- The **insured vehicle** has covered less than 10,000 miles; and
- The vehicle was supplied as new from within the **geographical limits**.

In these circumstances **we**, if asked by **you**, may replace the **insured vehicle** (and pay delivery charges) with a new vehicle of the same make, model and specification. **We** can only do this if a replacement vehicle is available in the **geographical limits** and anyone else who has an interest in the vehicle agrees.

If a replacement vehicle of the same make, model and specification is not available, **we** may, where possible, provide a similar vehicle of identical list price. If this is not acceptable to **you** **we** will not pay more than the **market value** or **written down value** of the **insured vehicle** at the time of the loss.

Once a settlement has been agreed in accordance with this new vehicle cover, the lost or damaged vehicle becomes **our** property.

If the **insured vehicle** is the subject of a Hire Purchase or Lease Agreement **we** will only agree settlement on the basis of this new vehicle cover if **we** have the agreement of the Hire Purchase or Lease Company as owner of the **insured vehicle**.

Repairs

Contact the Claims Helpline as soon as possible if **your insured vehicle** is damaged as a result of an incident covered by this policy. Claims advisers are there to assist **you** and will guide **you** through the repair process.

If parts required for repairing the **insured vehicle** are not available in any country contained within the **geographical limits** our liability for those parts shall not exceed the manufacturers' last United Kingdom list price or if not listed the price of those parts for the nearest comparable vehicle available in any country contained within the **geographical limits**. **We** will not pay the cost of importing parts that are not available in any country contained within the **geographical limits**.

We may at **our** option use parts that have not been supplied by the original manufacturer to repair the **insured vehicle**. These parts will be subject to any part manufacturer's guarantee.

We will not pay the cost of any repair or replacement which improves the **insured vehicle** to a better condition than it was in before the loss or damage. If this does happen **you** must make a contribution towards the cost of repair or replacement. **You** may be required to contribute to the cost of replaced items such as exhausts or tyres.

Protection and Recovery

If the **insured vehicle** cannot be driven following an incident leading to a valid claim under this section, **we** will pay:

- the cost of its protection and removal to the nearest **approved repairer**, competent repairer or nearest place of safety; and
- the cost of re-delivery after repairs to **your** home address; and
- the cost of storage of the **insured vehicle** incurred with **our** written consent.

If the **insured vehicle** is damaged beyond economical repair **we** will arrange for it to be stored safely at premises of **our** choosing.

You should remove your **personal belongings** from the **insured vehicle** before it is collected from **you**.

In the event of a claim being made under the policy, **we** have the right to remove the **insured vehicle** to an alternative repairer, place of safety or make **our** own arrangements for re-delivery at any time in order to keep the cost of the claim to a minimum.

Guidance Notes - Preventing Crime

- Don't give criminals an easy ride. Vehicle crime makes up 20% of all recorded crimes in the UK.
- Most thefts can be prevented - and it's in your interest and ours to take some simple precautions. Most things are common sense.
- Lock your vehicle and remove your ignition key/locking device when leaving it for even a short time e.g. at a petrol station or cashpoint machine.
- Vehicle thieves often steal the keys first especially if the vehicle has an immobiliser and break into houses just to access keys to steal the vehicle. Always keep keys secure even inside your home (do not leave keys where a burglar can easily find them).
- Keys and locking devices should always be kept in a safe and secure place - do not leave them on a wall hook, windowsill or in a jacket pocket close to the vehicle.
- Take appropriate measures to safeguard the vehicle when showing it to prospective purchasers.
- Do not keep items such as the vehicle registration document, service book, MOT certificate or certificate of insurance in the vehicle and never leave any valuables on view in the vehicle. You should remove items such as CD players, Radios/MP3 players and portable satellite navigation equipment whenever possible.
- Use good-quality locks and security devices.
- Park in a secure place if you can. If you have a garage, use it and lock it.

Exceptions to Sections A & B

What is not covered

These sections of **your** insurance policy do not cover the following:

- The amount of any **excess** shown in the **Policy Schedule** or in this policy document or in any **endorsement** that applies.
- Indirect losses which result from the incident that caused **you** to claim, for example, **we** will not pay compensation for **you** not being able to use the **insured vehicle**.
- Wear and tear, mechanical or electrical breakdown including failure of any equipment, integrated circuit, computer chip, computer software or computer related equipment and failure or breakages of any part due to application of brakes or road shocks.
- Depreciation or loss of value following repairs.
- Loss of or damage caused by someone taking the **insured vehicle** without **your** permission, unless the incident is reported to the police and assigned a crime reference number and **you** do not subsequently make any statement to the police that the **insured vehicle** was taken with **your** permission.
- Loss suffered due to any person obtaining any property by fraud or deception, for example a purchaser's cheque not being honoured by their bank.
- Loss or damage to the **insured vehicle** where possession of it is gained by deception on the part of someone pretending to be a buyer or someone pretending to act on behalf of a buyer.
- Loss or damage to the **insured vehicle** as a result of:
 1. lawful repossession
 2. return to its rightful owner
 3. seizure by the police or their authorised representatives.
- Loss or damage caused by pressure waves from aircraft or any flying object.
- Loss of or damage to keys, lock or ignition activators, alarm or immobiliser activators (except as insured under Section I of this insurance - Replacement Locks).
- Repairs, re-programming or replacement of any component, including locks on the **insured vehicle**, resulting from the loss of or damage to the **insured vehicle** keys, lock or ignition activators or alarm or immobiliser activators (except as insured under Section I of this insurance - Replacement Locks).
- Loss of or damage to the **insured vehicle** and/or **in-vehicle entertainment, communication and navigation equipment** while the **insured vehicle** is left **unattended** arising from theft or attempted theft when:
 1. ignition keys have been left in or on the **insured vehicle**; or
 2. the **insured vehicle** has not been secured by means of door and boot lock; or
 3. any window or any form of sliding or removable roof or hood have been left open or unlocked; or
 4. the **insured vehicle** is fitted with a manufacturer's standard security device and the device is not operational or is not in use.
- Loss or damage caused by an inappropriate type or grade of fuel being used.
- Confiscation, requisition or destruction by or under the order of any Government or Public or Local Authority.
- Damage to tyres caused by braking, punctures, cuts or bursts.
- Damage caused by frost unless **you** took precautions to protect the **insured vehicle**.
- Loss or damage caused deliberately by **you** or by any person who is in charge of the **insured vehicle** with **your** permission.
- Any amount **you** are contractually obliged to pay under any lease or finance agreement, **you** have entered into, over and above the cost of replacing the **insured vehicle**.

- Loss of or damage caused by Fire, theft or attempted theft whilst **your insured vehicle** is in storage unless:
 - **your insured vehicle** is stored at **your** private address; or
 - **your insured vehicle** is stored in a securely locked and alarmed building; or
 - **your insured vehicle** is stored in a professional storage facility which has been agreed by **us**.
- Damage resulting from fire or explosion in connection with the on-board domestic gas supply where the supply is not fitted or serviced in accordance with the Gas Safety (Installation and Use) Regulations.
- Damage caused by domestic animals, moth, vermin or infestation.
- Damage caused by rust, damp, wet or dry rot or any gradually operating cause.
- Damage caused by the process of cleaning, washing, repairing or restoring.
- The cost of replacing any undamaged items forming part of a set, suite or other articles of the same design when damage/loss occurs and replacements cannot be matched.
- Equipment whilst kept outside of **your** Motorhome which is not secured by a security device.

Section C - Liability to Other People

What is covered

Use of the insured vehicle

We will cover the categories of people listed below for their legal liability for death, bodily injury or damage to property arising out of the use of the **insured vehicle**;

- **You**; and
- any person permitted to drive the **insured vehicle** under the **Certificate of Motor Insurance** who is driving with **your** permission; and
- any passenger in the **insured vehicle**; and
- any person using (but not driving) the **insured vehicle** for social domestic and pleasure purposes with **your** permission; and
- the employer or business partner of any person named as a permitted driver on **your Certificate of Motor Insurance** in the event of an accident occurring while the **insured vehicle** is being used for business by that named person as long as **your Certificate of Motor Insurance** allows business use by such person.

Towing

You are covered while any vehicle covered by this policy is towing a trailer or broken down vehicle. The cover will apply as long as the towing is allowed by law and the trailer or broken down vehicle is attached properly by towing equipment made for this purpose.

Third Party Property Damage Limit

The most **we** will pay for property damage for any one claim, or series of claims arising out of any one event is £20,000,000. The most **we** will pay in legal costs for any one property damage claim or series of property damage claims arising out of any one event is £5,000,000.

Legal Costs

In the event of an accident covered by this section and subject to our prior agreement **we** will pay for the following at **your** request:

- Solicitors' fees for representation at any coroner's inquest, fatal accident inquiry or magistrates court (including a court of equal status in any country within the **geographical limits**).
- Legal costs for defending a charge of manslaughter or causing death by dangerous or careless driving.
- Any other costs and expenses for which **we** have given prior agreement.

If anyone who is covered by this section dies while they are involved in legal action, **we** will give the same cover applicable under this section of the policy to their legal personal representatives.

Driving Other Vehicles

You are not allowed to drive any other vehicle under the terms of this policy other than the vehicle as shown on **your Certificate of Motor Insurance**.

Emergency Medical Treatment

We will pay emergency treatment charges required by the Road Traffic Acts. If this is the only payment **we** make, it will not affect **your** No Claim Bonus.

Exceptions to Section C

What is not covered

We shall not be liable:

- if the person claiming is otherwise insured; or
- for loss or damage to property belonging to or in the care of any person insured under this section or for not being able to use any such property; or
- for damage to the **insured vehicle** or property in it or being conveyed in it or for not being able to use any such property; or
- for loss or damage to any trailer or caravan being towed by the **insured vehicle** or for any property carried in or on that trailer or caravan or for not being able to use any such trailer or caravan; or
- for death or bodily injury to any person being carried in or on any trailer or caravan; or
- when a trailer or broken down vehicle is being towed for profit; or
- for any loss incurred while the trailer or broken down vehicle is not attached to the **insured vehicle**.
- if the death of or bodily injury to any person covered under this section arises out of or in the course of his/her employment except where such liability must be covered under the Road Traffic Acts; or
- if a person who was not driving makes a claim and he/she knew that the person driving did not hold a valid driving licence; or
- for any loss, damage, death or injury arising as a result of a 'road rage' incident or caused deliberately by **you** or any other person claiming under this policy except where such liability must be covered under the Road Traffic Acts; or
- for any claim resulting from carrying, preparing, selling or supplying of any goods, food or drink from the **insured vehicle**.

Section D - Provision of a Courtesy Vehicle

21

SECTION D

Cover under this policy section does not apply.

Section E - Personal Accident Benefits

This section applies only if the cover shown on **your Policy Schedule** is Comprehensive.

What is covered

If **you** or **your partner** are accidentally killed or injured within the **geographical limits**, the European Union or EEA while **you** are travelling in or getting out of the **insured vehicle** we will pay for the following;

- For Death - £5,000
- For the total and irrecoverable loss of sight in one or both eyes - £5,000
- For the permanent loss (at or above the wrist or ankle) of use of one or more hands or feet - £5,000

We will only pay these amounts if the death or loss happens within 3 calendar months of the accident.

What is not covered

We will not pay for:

- More than £10,000 per claim
- Death or injury to any person not wearing a seat belt when required to by law
- Any intentional self injury, suicide or attempted suicide
- Any injury or death to any person driving at the time of the accident who is found to have a higher level of alcohol or drugs in their body than is allowed by law
- While **you** or **your partner** has any other vehicle insurance policy with us, **we** will only pay the benefit under one policy.

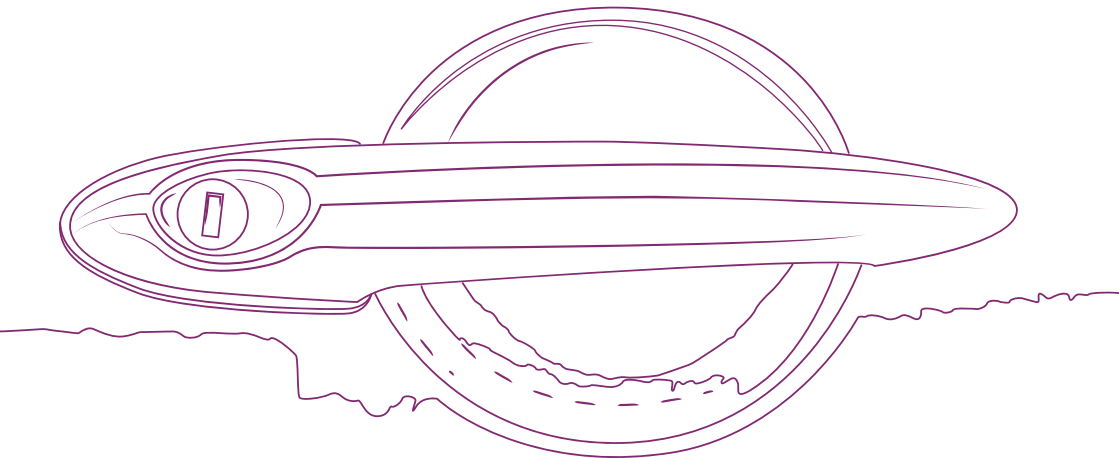

Section F - Contents and Equipment

This section applies only if the cover shown on **your Policy Schedule** is Comprehensive.

What is covered

Payment of claims for loss or damage to contents and **equipment** kept in **your insured vehicle**.

We will pay **you** up to a total of £2000 for Contents with a maximum single article limit of £300, if they are lost, stolen or damaged because of accidental damage, fire or theft, whilst kept in **your insured vehicle**.

We will also cover accidental loss or damage to **your equipment** up to £1000, whilst it is in **your insured vehicle** or whilst outside of **your insured vehicle** if secured by a security device.

We will, at **our** reasonable option:

- pay the cost of repairs or pay **you** in cash the amount of any loss or damage where repair cannot be economically made; or
- replace **your** contents and/or **equipment** with items of the same **market value** or pay **you** in cash for the loss or damage where **your** contents and/or **equipment** is stolen and not recovered or damaged beyond economical repair. The stolen or damaged items will then belong to **us**.

Cover for contents and **equipment** is not 'new for old' and a deduction will be made for wear and tear. The full **market value** must be disclosed at the inception of **your** policy and in the event of a loss, if the full value has not been disclosed, **you** will only be entitled to recover from **us** the proportion of the loss that the declared value bears to the total value of **your** property.

A depreciation deduction of 10% for each year of ownership, up to a maximum of 6 years, will be made to the items claimed for under this section of the policy.

Proof of ownership will be required for these items.

For example:

Item purchase price	£100	
	Age of item	Depreciated value of item
	12-24 months	£90.00
	25-36 months	£81.00
	37-48 months	£72.90
	29-60 months	£65.61
	61 months +	£59.05

What is not covered

Loss of or damage to:

- telephones or two-way radio transmitters or receivers or any radar detection **equipment**.
- money, stamps, tickets, documents, securities, lottery tickets, raffle tickets, promotional vouchers or Air Miles vouchers.
- goods, tools or samples carried in connection with any trade or business.
- property that is covered under any other policy.
- Damage resulting from Fire or explosion in connection with the on-board domestic gas supply where the supply is not fitted or serviced in accordance with the Gas Safety (Installation and Use) Regulations.
- Damage arising from domestic animals, moth, vermin or infestation.
- Damage caused by rust, damp, wet or dry rot or any gradually operating cause.
- Damage caused by the process of cleaning, washing, repairing or restoring.
- The cost of replacing any undamaged items forming part of a set, suite or other articles of the same design when damage/loss occurs and replacements cannot be matched.

- **Equipment** whilst kept outside of **your insured vehicle** which is not secured by a security device.
- Loss of, theft of, or damage to contents or **equipment** whilst **you** are not in the **insured vehicle** if the **insured vehicle** is left without being locked and/or if any window, roof opening, removable roof panel or hood is left open or unlocked.
- The cost of reinstating data from portable audio **equipment**, multi-media **equipment**, communication **equipment**, personal navigation and radar detection systems.

Section G - Medical Expenses

This section applies only if the cover shown on **your Policy Schedule** is Comprehensive.

What is covered

We will pay for:

The medical expenses for each person who suffers any injury arising from an accident while the person is in the **insured vehicle**. Up to a maximum of £200 for each injured person.

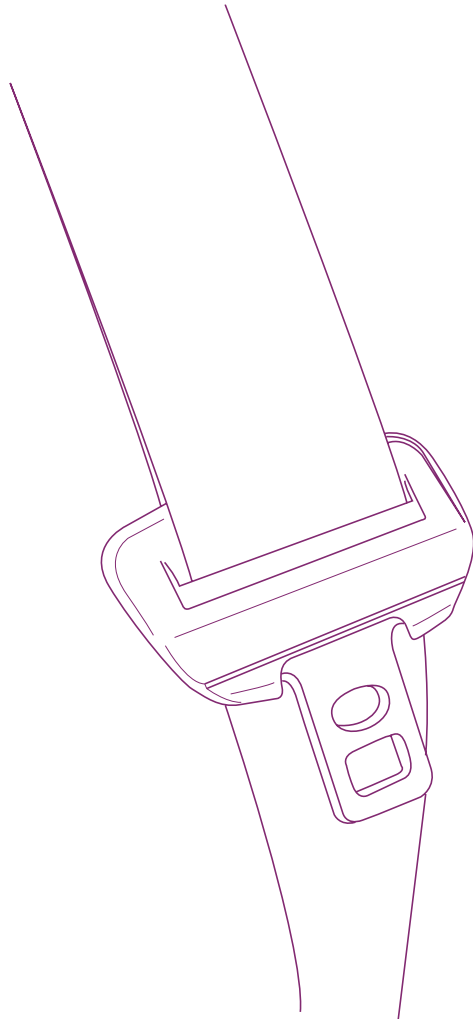

Section H - Glass Damage

This section applies only if the cover shown on **your Policy Schedule** is Comprehensive.

In the event of an incident likely to give rise to a claim for damaged glass please contact the **24 hour Claims Helpline on 0344 873 8183**.

What is covered

If the glass in the front windscreen or side or rear windows of the **insured vehicle** is damaged during the **period of insurance** we will pay the cost of repairing or replacing it. **We** will also pay for any repair to the bodywork of the **insured vehicle** that has been damaged by broken glass from the windscreen or window.

If the **insured vehicle** is fitted with Advanced Driver Assistance Systems (ADAS) **we** will also pay for the recalibration of cameras or sensors fitted behind the windscreen to operate these systems, if required.

The maximum amount **we** will pay is £1000. This limit is subject to the deduction of the excess as shown in **your policy schedule**. An excess will not apply if the damaged windscreen or window is repaired rather than replaced.

If this is the only damage **you** claim for and the cost of the claim is equal to or less than the maximum amount of £1,000 **your** No Claims Bonus will not be affected.

We may at **our** option use parts that have not been supplied by the original manufacturer. If **you** insist that **we** use parts supplied by the original manufacturer even though alternative non-original manufacturer parts are available **you** will be required to pay **us** any difference in the cost of such parts.

If an incident occurs involving the breakage of multiple items of glass **we** will only pay for one piece of glass under this section of the policy. Alternatively the damage can be claimed for under either Section A or B of the

policy and the **excess** applicable to that section of the policy will apply and **your** no claim bonus will be affected.

A claim solely under this section will not affect **your** no claim bonus.

What is not covered

We will not pay for:

- The glass **excess** shown in **your policy schedule** where the glass is replaced. Any claim for repair will not be subject to payment of an **excess**.
- Loss of use of the **insured vehicle**.
- Repair or replacement of any windscreen or window not made of glass.
- The cost of importing parts or storage costs caused by delays where the parts are not available from stock within the **geographical limits**.
- The cost of mechanical items associated with the window mechanism of the **insured vehicle** under this section.
- Any loss or damage caused deliberately by **you** or by any person who is in charge of the **insured vehicle** with **your** permission.
- The repair or replacement of sunroofs, **panoramic roof**, lights/reflectors or folding rear windscreen assemblies or any permanently fitted accessories including glass contained within hard tops under this section. Cover for these items will be supplied under Section A of this policy.

Section I - Replacement Locks

This section applies only if the cover shown on **your Policy Schedule** is Comprehensive.

What is covered

If the lock transmitter, keys or other ignition activation device to the **insured vehicle** are lost or stolen **we** will pay for:

A maximum of £500, after deduction of the £100 **excess**, under this section towards the cost of replacing the following:

- the door locks and/or boot lock;
- ignition/steering lock;
- the keys or ignition activation device or the lock transmitter and central locking interface;
- the cost of protecting the **insured vehicle**, transporting it to the nearest repairers when necessary and delivering it after repair to your home address.

Provided it can be established that the identity or the risk address of the **insured vehicle** is likely to be known to any person in receipt of such items.

What is not covered

We will not pay:

- The first £100 of any claim; or
- Any claim where the keys, lock activation device or the lock transmitter and central locking interface are either:
 - left in or on the **insured vehicle** at the time of the loss; or
 - taken without **your** permission unless the incident is reported to the police and assigned a crime reference number and **you** do not subsequently make any statement to the police that the keys or lock activation device were taken with **your** permission.
- the cost of replacing alarms or other security devices used in connection with the **insured vehicle** under this section of the policy.
- any amount in excess of £500

Section J - Foreign Use of the Insured Vehicle

What is covered

We will provide the cover shown on **your policy schedule** for up to 180 days in any **period of insurance** while **you** are using the **insured vehicle** within the countries referred to below.

Outside of the 180 day cover shown above **we** will provide **you** with the minimum cover required by law while **you** or any driver covered by this policy are using the **insured vehicle** within the European Union and any other country which has agreed to follow the EU Directive on Insurance of Civil Liabilities arising from the use of motor vehicles (number 2009/103/EC).

You do not need an International Motor Insurance Card (Green Card) for visits to these countries as the legal evidence of this cover is shown on **your Certificate of Motor Insurance**. Further information on the countries that follow the EU Directive can be found by visiting www.mib.org.uk

The provision of the cover shown on **your policy schedule** whilst you are abroad is only agreed on the understanding that:

- The **insured vehicle** is taxed and registered within the **geographical limits**; and
- Your main permanent home is within the **geographical limits**; and
- Your visit abroad is only temporary; and
- You tell your **insurance intermediary** before you leave; and
- You pay any additional premium **we** ask for.

We may agree to extend the cover for more than 180 days as long as **you**:

- Tell your **insurance intermediary** before you leave
- Pay any additional premium due.

If **we** agree to **your** request we may issue **you** with an International Motor Insurance Card (Green Card) as legal evidence of this cover.

The insurer will also pay customs duty if the **insured vehicle** suffers loss or damage and **we** decide not to return it after a valid claim on the policy.

Cover also applies while the **insured vehicle** is being carried between sea or air ports or railway stations within these countries, as long as this travel is by a recognised sea, air or rail route.

Section J - Foreign Use of the Insured Vehicle (continued)

Guidance Notes - Going Abroad

The policy does not automatically provide full cover abroad so, before travelling, please contact your insurance intermediary to arrange cover. The extended full insurance will then cover you in the countries for which we have agreed to provide cover and when your vehicle is travelling by rail or sea between those countries.

Unless you notify your insurance intermediary in advance of a trip abroad, the cover may be limited to the minimum cover you need under the law of the relevant country (EU minimum insurance). This minimum insurance will not provide any cover for damage to or theft of your insured vehicle.

Take your certificate as evidence of insurance when you travel abroad.

If your insured vehicle suffers any loss or damage that is covered by this insurance

and the insured vehicle is in a country where you have cover, we will refund any customs duty you pay to temporarily import your insured vehicle.

Although full policy cover abroad is available for up to 180 days in any one annual period of insurance we may, on request, agree to extend cover. A charge may apply. Please contact your intermediary for further information.

We will only consider extending this insurance to countries which are covered by the International Green Card system.

If you are involved in any accident or incident whilst abroad please call the 24 hour Claims Helpline using the international dialling code for the UK: 0044 344 873 8183.

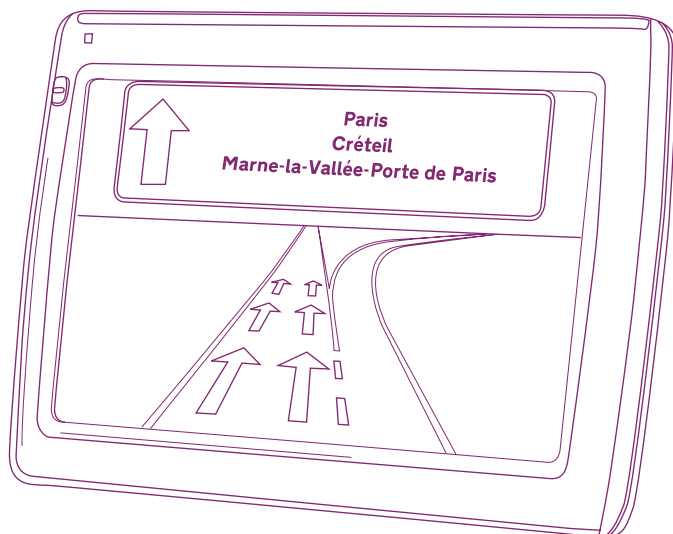

Section K - No Claim Bonus

If **you** do make a claim during the **period of insurance your** no claim bonus will be reduced at the next renewal date in accordance with the scale shown below.

The following will not affect **your** no claims bonus:

- Payments made under Section H - Glass damage.
- A successful claim made under Section M - Uninsured driver and vandalism promise
- If **we** only have to pay for an emergency treatment fee.
- If **we** make a full recovery of all payments made by **us** in connection with a claim made against the policy.

If **you** make a claim or if a claim is made against **you** for an event which **you** may not consider to be **your** fault and **we** have to make a payment this will affect **your** No Claim Bonus unless **we** can recover **our** outlay in full from the responsible party.

If **you** decide to cancel **your** policy and premiums remain outstanding **we** will not be able to issue proof of No Claim Bonus until the outstanding premiums are paid.

You cannot transfer **your** No Claim Discount to somebody else.

Guidance Notes – No Claim Bonus

There may on occasions be incidents (possibly involving a cyclist or pedestrian) where, although you are not claiming for damage to your vehicle, there is a potential for a claim against your policy by the third party.

In these circumstances we may disallow your No Claim Bonus for up to twelve months until we are confident that a third party claim is unlikely to materialise.

Current years NCB	Your NCB years at renewal if no fault claims made	Your NCB years at renewal if one fault claim made	Your NCB years at renewal if two fault claims made	Your NCB years at renewal if more than two fault claims made
0	1	0	0	0
1	2	0	0	0
2	3	0	0	0
3	4	1	0	0
4	5	2	0	0
5	6	3	1	0
6	7	3	1	0
7	8	3	1	0
8	9	3	1	0
9+	9+	3	1	0

Section L - Protected No Claim Bonus

Depending on certain qualifying conditions **you** may be able to protect your no-claim bonus if you pay an extra premium. **Your** no-claim bonus is only protected if this is shown on **your** schedule.

If **your** no-claim bonus is protected we will not reduce it if **you** do not make more than two claims during any three years of insurance. If three or more claims are made during any three-year period, we will reduce the bonus **you** receive.

It does not mean that **your** premium will not be increased if, for example, **your** accident or conviction record justifies this.

Section M - Uninsured Driver and Vandalism promise

This section applies only if the cover shown on **your policy schedule** is Comprehensive.

Uninsured driver promise

If the **insured vehicle** is involved in an accident that was not **your** fault or that of the driver of the **insured vehicle** and caused by an uninsured motorist **we** will refund the cost of **your excess** and restore **your** No Claim Bonus.

We will need:

- The vehicle registration and the make/model of the third party vehicle
- The responsible driver's details, if possible.

It also helps **us** to confirm who is at fault if **you** can get the names and addresses of any independent witnesses, if available. When **you** claim, **you** may have to pay **your excess**. Also, if when **your** renewal is due, investigations are still ongoing, **you** may lose **your** No Claim Bonus temporarily. However, once **we** confirm that the accident was the fault of the uninsured driver, **we** will repay **your excess**, restore **your** No Claim Bonus and refund any extra premium **you** have paid.

Vandalism promise

This section applies only if the cover shown on **your policy schedule** is Comprehensive.

If **you** make a claim for damage to **your insured vehicle** that is a result of vandalism, which is damage caused by a malicious and deliberate act, **you** will not lose **your** No Claim Bonus.

Conditions

- **You** pay any Accidental Damage **excess** that is applicable. Please refer to **your policy schedule** for **excess** amounts
- The incident is reported to the police and assigned a crime reference number
- The damage has not been caused by another vehicle.

When **you** claim **you** will have to pay the **excess**. Once **we** receive **your** claim, **you** may lose **your** No Claim Bonus, until **we** are supplied with a relevant crime reference number.

Section N - Emergency Transport & Accommodation

Section O - Child Car Seat

This section applies only if the cover shown on your **policy schedule** is Comprehensive.

What is covered

If **you** are not able to drive the **insured vehicle** as a result of an incident which is covered under section A or B of this policy **we** will assist with getting **you** and **your** passengers to a safe location. **We** will also pay you up to £100 per person in respect of:

- Alternative travel expenses for **you** and all occupants of the **insured vehicle** to reach **your** destination; or
- Emergency overnight accommodation for **you** and all occupants of the **insured vehicle** when an unplanned overnight stay is necessary.

What is not covered

- More than £500 per incident
- Reimbursement for the purchase of any drinks, meals, clothing, toiletries, newspapers or telephone calls
- Any additional costs incurred for the transportation of any goods carried within the **insured vehicle**
- Coverage outside the **geographical limits** of **your** policy.

This section applies only if the cover shown on **your policy schedule** is Comprehensive.

What is covered

If **you** have a child car seat fitted to **your insured vehicle** and **your insured vehicle** is involved in an incident where the damage to the **insured vehicle** is covered by this policy **we** will cover **you** for the cost of replacing the child car seat with a new one of a similar standard, even if there is no apparent damage, provided **you** are able to supply a copy of the original purchase receipt for the car seat.

General Exceptions

These General Exceptions apply to the whole of the insurance policy.

What is not covered

1. Excluded uses and excluded drivers

We will not cover any liability, loss or damage arising while any vehicle covered by this insurance is being:

- 1.1 used for a purpose which is not permitted or is excluded by the **Certificate of Motor Insurance**; or
- 1.2 used on the Nurburgring Nordschleife or deregulated/derestricted toll roads or any race track, racing circuit or prepared course unless **you** have told **us** about this and **we** have agreed to provide cover; or
- 1.3 driven by, is in the charge of or was last in the charge of anyone not permitted to drive by **your Certificate of Motor Insurance** or temporary cover note or who is excluded by **endorsement**; or
- 1.4 driven by, is in the charge of or was last in the charge of anyone including **you** who is disqualified from driving or has never held a licence to drive a vehicle or is prevented by law from having a licence; or
- 1.5 driven by any person who holds or last held a provisional driving licence unless that person is accompanied by a full licence holder aged 21 years or over and the accompanying full licence holder has held a full driving licence for at least 3 years; or
- 1.6 driven by, is in the charge of or was last in the charge of any person who does not meet the terms or conditions of his/her driving licence; or
- 1.7 used in an unsafe condition or while carrying an insecure load or while carrying a number of passengers that is likely to affect the safe driving of the vehicle; or

1.8 driven by **you** or any person insured to drive, should it be proved to **our** satisfaction that the driver was under the influence of alcohol or drugs at the time of such loss or damage occurring. A conviction under the relevant law (including a conviction for failing to supply a specimen of breath, blood or urine) shall be deemed to be conclusive evidence that the driver at the time of the loss or damage was under the influence of alcohol or drugs. In addition, you or any insured driver must repay all the amounts we have paid arising from the incident including any claimants' damages and costs.

1.9 driven by any person who fails to take medication as prescribed or carry out prescribed treatment or report for a medical examination recommended by a doctor where this inaction contributes to an accident.

General Exception 1 will not apply:

- if the **insured vehicle** has been stolen or taken away without **your** permission; or
- if the **insured vehicle** is temporarily in custody of a motor trader for repair or servicing; or
- being parked by an employee of a hotel or restaurant as part of a vehicle-parking service; or
- under General Exception 1.1 only, while the **insured vehicle** is being used for car sharing purposes as defined in General Condition 9 of this policy.

2. Overseas use

We will not make any payments for any liability, loss or damage that occurs outside of the **geographical limits** of this policy unless extended under the terms of Section J - Foreign Use (apart from the minimum cover required by law).

Additionally **we** will not make any payments in respect of any proceedings brought against **you** or judgement passed in any court outside of the **geographical limits**, unless the proceedings or judgement arise out of the **insured vehicle** being used in a foreign country which **we** have agreed to extend this insurance to cover and the proceedings or judgement are brought in such country.

3. Contractual liability

We will not cover any liability you have accepted under an agreement or contract unless **you** would have had that liability anyway.

4. Radioactivity

We will not cover any legal liability of whatsoever nature directly or indirectly caused by or contributed to or arising from:

- ionising radiations or contamination by radioactivity from any irradiated nuclear fuel or from any nuclear waste from the combustion of nuclear fuel; or
- the radioactive toxic explosive or other hazardous properties of any explosive nuclear assembly or nuclear component.

5. War

We will not pay for any loss, damage or liability arising as a consequence of war invasion or act of foreign enemy, hostilities (whether war be declared or not), civil war, rebellion, revolution, insurrection or military or usurped power.

6. Earthquake, riot and civil commotion

We will not pay for death, bodily injury, loss, damage and/or liability arising during (unless **you** prove that it was not occasioned thereby) or in consequence of:

- earthquake; or
- riot or civil commotion occurring elsewhere other than in Great Britain, the Isle of Man or the Channel Islands.

7. Use on airfields

We will not cover any liability in respect of:

- any accident, loss or damage to any aircraft; or
- death or bodily injury arising in connection with any accident, loss or damage to any aircraft; or
- any other loss indirectly caused by such accident, loss or damage to any aircraft incurred, caused or sustained while any vehicle covered by this insurance is in or on any airport or airfield.

8. Pollution

We will not pay for any liability, loss or damage resulting from pollution or contamination however caused, other than as required by the law of any country in which **we** have agreed to provide cover under this policy.

9. Terrorism

We will not cover any liability, loss or damage caused by acts of **terrorism** apart from the minimum level of cover **we** must provide by law.

General Conditions

These General Conditions apply to the whole of the insurance policy.

1. Payment of Premium, Keeping to the Policy Terms & Avoiding Misrepresentation

We will only provide the cover described in this insurance policy if:

- **you** have paid or agreed to pay the premium for the current **period of insurance**, and
- **you** or any person claiming protection has kept to all of the terms and conditions of this policy (including those applied by **Endorsement**) as far as they can apply, and
- in entering into this contract **you** have taken all reasonable care in answering all questions in relation to this insurance honestly and to the best of **your** knowledge.

Your premium is based on information **you** supplied at the start of the insurance, subsequent alteration or renewal. **You** must tell us via your **insurance intermediary** immediately of any change to that information, some examples are any changes to the **insured vehicle** which improve its value, attractiveness to thieves, performance or handling, any change of vehicle, change of occupation (including part-time), change of address (including where vehicle is kept), change of drivers, if **you** or any drivers pass **your** driving test or sustain a motoring or non-motoring conviction or there is a change of main driver.

If **your** premium has been calculated on a limited annual mileage basis **we** will seek evidence at the time of a claim to prove that **your** estimated annual mileage has not been exceeded. If **you** fail to supply appropriate evidence or evidence is provided by **you** which shows that the estimated annual mileage has been exceeded **you** will be required to pay the additional amount of **excess** shown on the **endorsement** applying to **your** policy.

Under the Consumer Insurance (Disclosure and Representations) Act 2012 **your** failure to take reasonable care to avoid misrepresentation in relation to the information provided could result in **your** policy being cancelled or **your** claim being rejected or not fully paid.

2. Looking after your vehicle

You or any permitted drivers are required to maintain the **insured vehicle** in a roadworthy condition. **You** or any person in charge of the **insured vehicle** are required to take all reasonable care to safeguard it and its contents from loss or damage, for example the vehicle should not be left unlocked.

We shall at all times be allowed free access to examine the **insured vehicle**.

3. Having an MOT certificate

There must be a valid Department for Transport test certificate (MOT) in force for the **insured vehicle** if one is needed by law. In the absence of a valid Department for Transport test certificate (MOT) all cover under sections A and B of this insurance is cancelled and of no effect.

4. Accidents or losses

In the event of an accident or incident likely to give rise to a claim which is covered under the policy, **you** must as soon as possible telephone the 24 hour Claims Helpline (this must be within 24 hours of the incident occurring). Please also refer to Page 4 of this policy booklet 'What to do in the Event of an Accident' for further guidance.

If the loss or damage is covered under the policy, the Claims Helpline operator will make arrangements to remove the **insured vehicle** to the nearest competent repairer or place of safety, and safeguard the **insured vehicle** and its contents.

We will not pay for further damage to the **insured vehicle** if **you** drive it or attempt to drive it in a damaged condition.

If your claim is due to theft, attempted theft, malicious damage or vandalism, you must also notify the police within 24 hours of discovery of the loss or as near as practical and obtain a crime report number.

If the **insured vehicle** is stolen and is no longer under your control we will remove it from the Motor Insurance Database (MID) until such time as it is recovered.

Important: If you are advised that your stolen vehicle has been recovered following its theft and it is roadworthy, it is important that you notify your insurance intermediary immediately and before you drive the vehicle, so that we can reinstate it onto the Motor Insurance Database otherwise you run the risk of being stopped by the police as they may suspect the vehicle is not insured.

We have the right to remove the **insured vehicle** at any time to keep claims costs to a minimum. If the **insured vehicle** is damaged beyond economical repair **we** will arrange for it to be stored safely at premises of **our** choosing.

If **we** ask to examine driving licences and vehicle documentation before agreeing to settle a claim under this policy **you** must supply this documentation before **we** can proceed with the settlement.

Any indication of a claim against **you** must be notified to **us** as soon as possible. Any writ, or notification of civil or criminal proceedings should be sent to **us** by recorded delivery immediately.

We shall be entitled to take over and conduct the defence or settlement of any claim or prosecute any claim in the name of any person covered by this insurance.

5. Claims procedures

No admission of liability, payment or promise of payment shall be made or given by **you** or any person on **your** behalf. No proceedings may be commenced against, or settlement accepted from, any other party without **our** written consent.

We shall have discretion in the conduct of any proceedings or in the settlement of any claim.

You must give us whatever co-operation, information and assistance **we** require in dealing with any claim under this policy such as evidence in support of a claim.

If there is any other insurance in force which covers the same loss, damage or liability as this insurance, **we** will only pay **our** proportionate share of the claim.

6. Cancellation

Cancelling the policy within the reflection period

This insurance provides **you** with a reflection period to decide whether **you** wish to continue with the full policy. The reflection period is for 14 days from the start date of your policy or date you receive **your** policy documentation.

If a period of less than 14 days has elapsed since **you** received **your** policy documentation, and **you** have not made a total loss claim, you have the right to cancel the policy and receive a refund of premium.

- If at the date of cancellation **your** policy has not yet commenced **you** will receive a full refund from **us**; or
- If **your** policy has already commenced, **we** will refund the premium relating to the remaining **period of insurance** calculated on a proportionate basis dependent on the number of days left to run under the policy less a charge of £25 plus Insurance Premium Tax if applicable to cover **our** administration costs.

General Conditions (continued)

Cancelling the policy after the reflection period

Cancellation by you

You or **your Insurance Intermediary** can cancel this policy either from the date **we** are notified, in writing, or a later date as requested by **you**. Providing there have been no claims in the current **period of insurance** **we** will refund the premium relating to the remaining **period of insurance** calculated on a proportionate basis dependent on the number of days left to run under the policy less an administration fee of no more than £50 plus Insurance Premium Tax if applicable to take into account **our** costs in providing **your** policy.

Cancellation by us

We can cancel this policy at any time if there are serious grounds to do so, including but not limited to the following examples:

- where **your insurance intermediary** has been unable to collect a premium payment (payment terms including the procedures in the event of non-payment of the premium will have been agreed between **you** and **your insurance intermediary** when **you** took out this policy); or
- **you** have failed to take reasonable care in providing information in relation to this insurance as required by General Condition 1 of this policy; or
- **you** have failed to supply requested validation documentation (evidence of No Claim Discount, copy driving licence, etc.); or
- **you** have failed to co-operate or provide information and assistance in relation to any claim under this policy or with regards to the administration or operation of this policy; or
- where **you** fail to maintain the **insured vehicle** in a roadworthy condition or **you** fail to look after it in accordance with General Conditions 2 and 3 of this policy; or
- where **you** use threatening or abusive behaviour towards a member of **our** staff or a member of staff of **your insurance intermediary** or **our** supplier.

We will do this by giving **you** 7 days' notice in writing to **your** last address notified to **us**. **Your** last notified address may include an email address nominated by **you** to accept correspondence.

We will refund the premium relating to the remaining **period of insurance** calculated on a proportionate basis dependent on the number of days left to run under the policy less an administration fee of no more than £50 plus Insurance Premium Tax if applicable to take into account **our** costs in providing **your** policy. The pro rata refund of premium (less the administration fee) is only available as long as:

- the **insured vehicle** has not been the subject of a total loss claim (i.e. written-off or stolen and not recovered); and/or
- cancellation is not due to any fraudulent act by **you** or anyone acting on **your** behalf.
- Please refer to General Condition 10 with regard to **our** cancellation policy involving fraudulent acts.

We also reserve the right to retain all premium paid for the current **period of insurance** in the event that a claim has been made against the policy during this period until such time as **we** recover any monies paid out by **us**.

Non-payment of premium

In the event that there has been a loss or incident likely to give rise to a claim during the current **period of insurance** and premium amounts are outstanding **we** may at **our** discretion reduce any claims payment by the amount of outstanding or overdue premiums that **you** owe **us** and/or **your insurance intermediary**.

Guidance Notes - Policy Cancellation

Please note that any refund from us whether during or after the reflection period may be subject to a further charge levied by your insurance intermediary. Any charges levied by your insurance intermediary will be in accordance with the terms and conditions agreed between you and them at the time you arranged this insurance.

7. Total losses and stolen vehicles

If as a result of a claim the **insured vehicle** is determined to be a total loss or **your** vehicle has been stolen and not recovered, this policy will be cancelled without refund of premium unless **you** change **your** vehicle to another that would normally be acceptable to **us** or the stolen vehicle is recovered and is not a total loss.

In the event of the policy being cancelled due to the **insured vehicle** being a total loss or stolen and not recovered, and there being no replacement vehicle to insure (or if there is a replacement vehicle to insure which is unacceptable to us), all outstanding or overdue premiums, including any administration charge due, must be paid immediately. **We** may at **our** discretion reduce the claims payment by the amount of outstanding or overdue premiums that **you** owe **us** and/or **your** **insurance intermediary**.

8. Right of recovery

If under the laws of any country in which this insurance applies, **we** have to make payments which but for those laws would not be covered by this policy, **you** must repay the amounts to us.

You or the person who caused the accident must also repay **us** any money **we** have to pay because of any agreement **we** have with the Motor Insurers' Bureau.

Any payment **we** have to make because **we** are required to do so by compulsory insurance law or an agreement with the Motor Insurers' Bureau will prejudice **your** No Claim Discount and will also mean that there will be no entitlement to a return of premium if the policy is cancelled or declared void.

9. Sharing arrangement

This policy allows **you** to carry passengers for social or similar purposes and **your** receipt of a mileage allowance or a payment by a passenger towards the cost of fuel will not invalidate cover as long as:

- **you** do not make a profit from the car sharing arrangement; and
- **your insured vehicle** is not adapted to carry more than eight people (including the driver); and
- **you** are not carrying passengers as customers of a passenger-carrying business.

10. Fraud

You must not act in a fraudulent manner. If **you**, an authorised driver or anyone acting on **your** behalf knowingly commit:

- a) a fraudulent act or submit a fraudulent document or make a fraudulent statement when obtaining this policy or at any other time during the policy period; or
- b) make a claim that is false, fraudulent or deliberately exaggerated, **we** will:
 - i) not pay the claim
 - ii) immediately cancel this policy and all other insurances currently in force with **us** with which **you** and any authorised driver are connected.
 - iii) not issue any refund of premium on this and all other insurances currently in force with **us** with which **you** and any authorised driver are connected.
 - iv) inform the police of the circumstances.

When cancelling this policy **we** reserve the right not to issue any postal notification of cancellation where it is known that the postal address has been used fraudulently.

11. Tax and registration

Your **insured vehicle** must be taxed where applicable and registered within the **geographical limits**.

Our Service Commitment

What to do if you have a complaint

We are dedicated to delivering a first class level of service to all policyholders. However, **we** accept that things can occasionally go wrong and would encourage you to tell us about any concerns **you** have so that **we** can take steps to make sure the service **you** receive meets **your** expectations in the future.

If a dispute regarding your policy or claim arises and cannot be resolved by reference to your insurance intermediary the following explains the procedures for resolving your complaint:

If **you** have a complaint, please contact **us** at the address below:

Markerstudy Customer Relations
Markerstudy Insurance Services Limited
PO Box 727
Chesterfield
S40 9LH
Tel: 0344 705 0633
Email: complaints@markerstudy.com

When contacting us please provide:

- A policy number and/or claim number.
- An outline of **your** complaint.
- A contact telephone number.

We will make every effort to resolve **your** complaint by the end of the third working day after receipt. If we cannot resolve **your** complaint within this timeframe we will acknowledge **your** complaint within five working days of receipt and do our best to resolve the problem within four weeks by sending **you** a final response letter. If we are unable to do so, we will write to advise **you** of progress and will endeavour to resolve **your** complaint in full within the following four weeks.

If we are still unable to provide **you** with a final response at this stage, we will write to **you** explaining why and advise when **you** can expect a final response. At this point **you** may refer **your** complaint to The Financial Ombudsman Service at the following address:

The Financial Ombudsman Service
Exchange Tower
Harbour Exchange Square
London
E14 9SR
Email: complaint.info@financial-ombudsman.org.uk

What you should know

You may go directly to the Financial Ombudsman Service when **you** first make **your** complaint, but the Ombudsman will only review **your** complaint at this stage with **our** consent. However, **we** are still required to follow the procedure stated above.

If **you** have received a final response but are dissatisfied, **you** have the right of referral to the Financial Ombudsman Service within six months of the date of your final response letter. **You** may only refer to the Ombudsman beyond this time limit if **we** have provided **our** consent.

Whilst **we** are bound by the decision of the Financial Ombudsman Service, **you** are not. Following the complaints procedure above does not affect **your** right to take legal action.

Online Dispute Resolution Platform (ODR)

The European Commission has an online dispute Resolution service for consumers who have a complaint about a product or service bought online. If you choose to submit your complaint this way it will be forwarded to the Financial Ombudsman Service.

Visit ec.europa.eu/odr to access the Online Dispute Resolution Service.

Customer feedback

If **you** have any suggestions or comments about **our** cover or the service **we** have provided please write to:

Markerstudy Customer Relations,
Markerstudy Insurance Services Limited,
PO Box 727,
Chesterfield
S40 9LH

We always welcome feedback to enable **us** to improve **our** products and services.

Telephone Recording

For **our** joint protection telephone calls may be recorded and monitored by **us**.

Financial Services Compensation Scheme

Markerstudy Insurance Services Limited is a member of the Financial Services Compensation Scheme (FSCS).

You may be entitled to compensation from this scheme if **we** cannot meet **our** liabilities under this policy.

Further information about the scheme is available on the FSCS website at www.fscs.org.uk or by writing to:

FSCS
PO Box 300
Mitcheldean
GL17 1DY

Your insurance intermediary

In the event that **we** are unable to continue to trade with **your insurance intermediary** because they have ceased to trade through bankruptcy or liquidation or in the event that their relevant FCA authorisation is revoked **we** reserve the right to pass **your** policy and all details on to another intermediary. If **you** do not wish this to happen then please put **your** request in writing to us.

How we use your information

Introduction

We believe in keeping your information safe and secure. Full details of what data we collect and how we use it can be found in our privacy policy which you can access via www.markerstudy.com or by requesting a copy from our Data Protection Officer (contact details below). This section provides you with some basic information and explains:

- What we do with your information.
- How we may check the information you have provided to us against other sources such as databases.
- Who we share your information with, and
- how we may use your information.

We are governed by the Data Protection legislation applicable in the United Kingdom.

How we may collect your information

We may collect details about you from

- Information you give to brokers.
- Information you give us in online forms and other forms.
- Other sources such as Google Earth and social media.
- Third parties and other sources.
- Telematics systems.

What information we may collect about you

We collect details including details about your health, personal circumstances, claims history, credit history, motoring history and other relevant details. We may collect information on you from databases such as the electoral roll and county court judgment records.

How we may share your information

In order to provide our services to you, we may share your information with insurance companies, solicitors, regulators, business partners and suppliers. We may also have a legal obligation to provide your information, in

certain circumstances, with regulators, police and other public bodies.

Information you supply may be used for the purposes of insurance administration by us and third parties. These third parties may share your information with their own agents.

How we may use your information

We may use your information for a number of purposes. These include:

- Providing you with our services.
- Dealing with your claim.
- Carrying out checks such as fraud checks and credit checks.
- Providing you with information about our products and services.

We give details about some of these processes below.

Driving Licence checks

We may also provide your (or any named third party) driving licence number (DLN) and other details to the DVLA to confirm licence status, entitlement and relevant restriction information and endorsement/conviction data.

Searches may be carried out prior to your policy commencing and at any point during your insurance policy including any mid-term adjustment and renewal stage. For details relating to information held about you by the DVLA please visit www.dvla.gov.uk.

The DVLA may also be used to search your (or any named third party's) no claims discount (NCD) details against a no claims discount database to obtain information in relation to your NCD entitlement.

We may pass details of your no claims discount to certain organisations to be recorded on a NCD database.

Providing you with details on our Products and Services

Where you have given us your consent to do so, we will send you information about products and services of ours and other companies in our Group which may be of interest to you. We may contact you by telephone, letter or email (as you have indicated)

You have a right at any time to stop us from contacting you for marketing purposes or giving your information to other members of the Group.

If you no longer wish to be contacted for marketing purposes then please contact our Data Protection Officer (contact details below).

Motor Insurance Database

Your policy details will be added to the Motor Insurance Database (MID), run by the Motor Insurers' Bureau (MIB). MID and the data stored on it, including your personal details, may be looked at and used by certain statutory and/or authorised bodies including the Police, the DVLA, the Insurance Fraud Bureau and other bodies permitted by law.

If you are involved in an accident (in the UK or abroad), insurers and/or the MIB may search the MID to obtain relevant information.

Persons pursuing a claim in respect of a road traffic accident (including citizens of other countries) may also obtain relevant information which is held on the MID.

It is vital that the MID holds your correct registration number. If it is incorrectly shown on the MID you are at risk of having your vehicle seized by the Police. You can check that your correct registration details are shown on the MID at www.askmid.com

Fraud Prevention and Detection

We carry out fraud checks on our customers. We do this in order to prevent fraud and also to help us make decisions about the provision, pricing and administration of insurance.

When carrying out these checks, we will search against fraud detection databases.

We may pass details about you to some of these databases.

Law enforcement agencies, financial service providers, fraud prevention agencies, police and other organisations may also access these databases.

Claims History

We may process data relating to your claims history for the purposes of assessing any claim you may make.

The aim is to help us to check information provided and also to prevent fraudulent claims. When you tell us about an incident we will pass information relating to it to these databases. We may search these databases when you apply for insurance, in the event of any incident or claim, or at time of renewal.

Credit Searches and Accounting

In assessing an application for insurance or policy renewal, we may search files made available to us by credit reference agencies. They keep a record of that search.

Credit reference agencies share information with other organisations, enabling applications for financial products to be assessed or to assist the tracing of debtors, or to prevent fraud.

Transfers

Sometimes your information may be transferred outside the European Economic Area by us, by the organisations with whom we share your information or by the servants and agents of these organisations. If we do this we will ensure that anyone to whom we pass it provides an adequate level of protection.

How we use your information (continued)

Your Rights as a Data Subject

Under Data Protection Laws you have certain rights; these include for example, a right to understand what data we hold on you and a right to ask us to amend that data if it is incorrect. If you would like to exercise any of your rights please contact our Data Protection Officer (contact details below).

Data protection officer

If you have any questions about how we use your data, or to exercise any of your data rights please contact our Data Protection Officer at

Data Protection Officer
Markerstudy Insurance Services Limited
45 Westerham Road
Bessels Green
Sevenoaks
Kent
TN13 2QB

Numbers to Call

Had an accident?

We're here to get you back on the road.

The procedure outlined below must be followed for all accidents, regardless of who was responsible. Even if you do not intend to make a claim for the damage to your vehicle you must still report the accident. Delay in notification may invalidate your right to claim.

Call 0344 873 8183

Please call within 24 hours of the accident, but ideally within 1 hour.

Does the accident involve a third party?

- Pass your details along with your policy number to the third party.
- If you are calling from the roadside an advisor may ask to speak to the third party, or ask you to request them to make contact on 0344 873 8183 within 1 hour.
- The third party may be entitled to a number of services free of charge (dependent on blame).

Motorhome Insurance Policy

www.markerstudy.com